

Butt Weld Carbon Cap

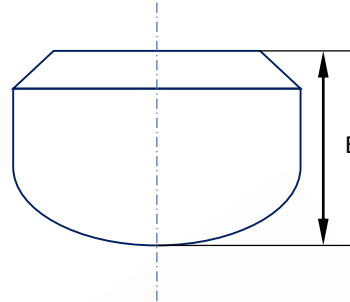

| Nominal pipe size | Outside diameter | E (mm) | CAP. Approx. Wt. Caps (Kg) | |
|-------------------|------------------|--------|----------------------------|-------|
| | | | STD | XS |
| 2 | 60,3 | 38 | 0,23 | 0,30 |
| 2-1/2 | 73,0 | 38 | 0,36 | 0,46 |
| 3 | 88,9 | 51 | 0,64 | 0,83 |
| 3-1/2 | 101,6 | 64 | 0,96 | 1,28 |
| 4 | 114,3 | 64 | 1,15 | 1,55 |
| 5 | 141,3 | 76 | 1,90 | 2,60 |
| 6 | 168,3 | 89 | 2,90 | 4,20 |
| 8 | 219,1 | 102 | 5,13 | 7,40 |
| 10 | 273,0 | 127 | 9,09 | 11,95 |
| 12 | 323,8 | 152 | 13,40 | 17,26 |
| 14 | 355,6 | 165 | 16,58 | 21,35 |
| 16 | 406,4 | 178 | 19,76 | 26,26 |